

DISTRICT HEATING

CIM/CIU COMMUNICATION INTERFACES

COMPLETE CONTROL FOR PUMPS AND PUMP SYSTEMS



MANAGE YOUR SYSTEMS WITH CIM/CIU COMMUNICATION INTERFACES

For complete control of pump systems, the Grundfos fieldbus concept is the right solution. The innovative Communication Interface Module (CIM) and the Communication Interface Unit (CIU) enable data communication via open and interoperable networks such as

- Modbus RTU
- Modbus TCP
- BACnet MS/TP
- BACnet IP
- LONWorks
- PROFIBUS DP
- PROFINET IO
- EtherNet/IP
- 3G/4G cellular data connection and SMS
- Connectivity to Grundfos iSOLUTIONS Cloud

The series of Grundfos CIM/CIU communication interfaces offer ease of installation and commissioning, user-friendliness and great value for money in the long term. The modules are based on standard functional profiles for an easy integration into the network and easy understanding of data points.

WHY CIM/CIU CONNECTIVITY INTERFACES?

- Pumps and controllers have better reliability with reduced downtime, due to monitoring and control functionality on a PLC, BMS/SCADA system
- The operational cost of pumps can be lowered by reducing setpoints to match precise system needs via remote control
- Remote monitoring and control via PLC, BMS/ SCADA systems reduce manual settings, monitoring time and travel time to sites or installations
- Enable predictive maintenance and fast reaction time on process changes and exceptions
- One solution for all products with a modular design prepared for future needs, offering complete process monitoring and control
- Allow SCADA systems or Grundfos cloud solutions to create reports and support answers by remote monitoring and analysis
- Flexible wide range power supply 24-240 VAC/VDC (CIU unit)
- Easy to install and commission, as Grundfos delivers the required support files and functional profile manuals

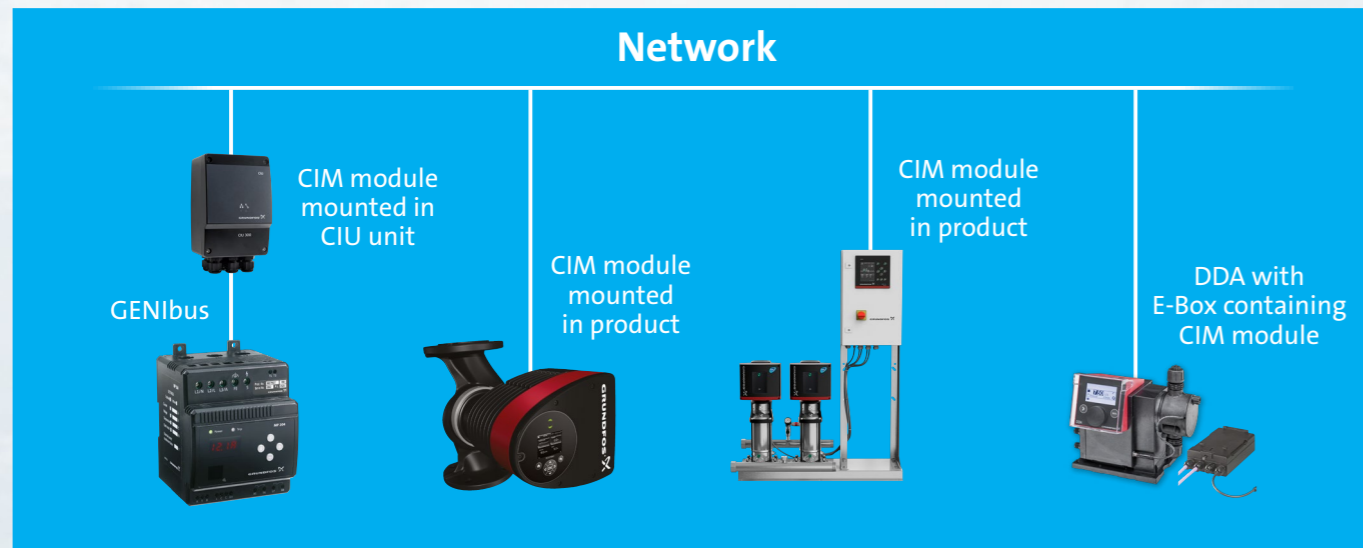

Available communication interfaces

- CIM 050 for GENIbus
- CIM 060 for radio communication to Grundfos GO Remote
- CIM 100/110 for LONWorks
- CIM 150 and E-Box 150 for PROFIBUS DP
- CIM 200 and E-Box 200 for Modbus RTU
- CIM 260 for 3G/4G cellular networks (EU)
- CIM 280 cellular to Grundfos iSOLUTIONS Cloud (EU/US)
- CIM 300 for BACnet MS/TP
- CIM 500 for PROFINET IO, Modbus TCP, BACnet IP, EtherNet/IP
- CIM 550 for Ethernet connection to Grundfos iSOLUTIONS Cloud
- E-Box 500 for PROFINET IO, Modbus TCP, EtherNet/IP
- CIU 900 unit for any CIM interface
- CIU 901 unit with IO board
- CIU 902 unit for wastewater AUTOADAPT
- CIU 903 for SQFlex/MG Flex
- GiM CIU unit for Grundfos iSOLUTION MONITOR

Grundfos Communication Interface Modules (CIM) and Units (CIU)

Creating intelligent communications solutions for applications in Industry, Building Services and Water Utility.

Mounting CIM in CIU unit or E-Box

	CIM	CIU 900	CIU 901 (IO 270)	CIU 902 (AUTOADAPT)	CIU 903 (SQ Flex/MG Flex)	Grundfos iSOLUTIONS MONITOR CIU	E-Box (Small DDA)
LONWorks	CIM 100/110	CIU 100/110 assembly					
PROFIBUS DP	CIM 150	CIU 150 assembly		CIU 152 assembly			E-Box 150
Modbus RTU	CIM 200	CIU 200 assembly	CIU 201 assembly	CIU 202 assembly		GiM CIU, built-in Modbus RTU	E-Box 200
BACnet MS/TP	CIM 300	CIU 300 assembly					
Cellular 3G/4G for SCADA	CIM 260 EU	CIU 260 EU assembly	CIU 261 EU assembly	CIU 262 EU assembly			
Cellular 3G/4G for Grundfos iSOLUTIONS Cloud	CIM 280-EU Grundfos iSOLUTIONS Cloud/CIM 280-US Grundfos iSOLUTIONS Cloud	CIM 280-EU Grundfos iSOLUTIONS Cloud/CIM 280-US Grundfos iSOLUTIONS Cloud assembly *)	CIM 280-EU Grundfos iSOLUTIONS Cloud/CIM 280-US Grundfos iSOLUTIONS Cloud assembly *)	CIM 280-EU Grundfos iSOLUTIONS Cloud/CIM 280-US Grundfos iSOLUTIONS Cloud assembly *)	CIM 280-EU Grundfos iSOLUTIONS Cloud/CIM 280-US Grundfos iSOLUTIONS Cloud assembly *)	GiM CIU, Grundfos iSOLUTIONS Cloud	
Industrial Ethernet	CIM 500	CIU 500 assembly	CIU 501 assembly, for Modbus TCP and Grundfos iSOLUTIONS Cloud only	CIU 502 assembly, for Modbus TCP, PROFINET, EIP, Grundfos iSOLUTIONS Cloud only	CIU 503 assembly Grundfos iSOLUTIONS Cloud/GRM only	GiM CIU, Grundfos iSOLUTIONS Cloud	E-Box 500
Ethernet - wired for Grundfos iSOLUTIONS Cloud	CIM 550	CIU 550 assembly *)	CIU 550 assembly *)	CIU 550 assembly *)	CIU 550 assembly *)	GiM CIU, Grundfos iSOLUTIONS Cloud	

Note: All devices denoted as "assembly" consist of two parts, that are ordered separately.

CIM modules

The CIM is an add-on communication module installed internally.

Single pumps:

- E-pumps based on MGE motor model H/I/J
- E-pumps based on MGE motor 11-22 kW
- MAGNA3 circulator pumps

Boosters:

- Hydro/Control MPC, CU 352
- DDD control, CU 354
- Hydro Multi-E and Hydro Multi-B
- MAGNA3-D twin circulator pumps
- TPED twin pump model H/I/J

Water Utility controllers:

- Dedicated Controls, CU 362
- Level Control, LC 2X1 wastewater, LC 2X2 submersible

CIU 900 wall-mounted/DIN rail unit

The CIU 900 with internal power supply is for Grundfos products that do not support the internal mounting of the CIM module.

- TPED 11-22 kW
- CUE drive for various standard pumps
- MP 204 motor protector
- DDA model XL

CIU 901 wall-mounted/DIN-rail unit

A CIU 900 unit with additional I/O board integrated which contains:

- 2 configurable inputs (digital or analog 0/4-20 mA, 0-10 V)
- 1 Relay output (230 V, 2 A)
- 1 Analog signal output (0-10 V)
- 1 Temperature input (Pt100/Pt1000, 2-wire)
- 2 digital inputs

Supported from CIM 200 Modbus RTU, CIM 260 3G/4G cellular, CIM 280-EU Grundfos iSOLUTIONS Cloud/CIM 280-US Grundfos iSOLUTIONS Cloud, CIM 500 (Modbus TCP)

*) Reach out to Grundfos to verify that your product is supported from the cloud as this depends on the available cloud driver.

CIU 902 wall-mounted/DIN rail unit

A CIU 900 unit but with integrated powerline communication to connect 1 to 4 wastewater AUTOADAPT pumps.

Supported from:

- CIM 150 PROFIBUS DP
- CIM 200 Modbus RTU
- CIM 260 cellular
- CIM 280-EU Grundfos iSOLUTIONS Cloud/CIM 280-US Grundfos iSOLUTIONS Cloud *)
- CIM 500 for Modbus TCP, PROFINET, EtherNet/IP

CIU 903 wall-mounted/DIN rail unit

A CIU 900 unit but with integrated powerline communication to connect wastewater MGEFlex and SQFlex pumps.

Supported from:

- CIM 280-EU Grundfos iSOLUTIONS Cloud/CIM 280-US Grundfos iSOLUTIONS Cloud

Grundfos iSOLUTIONS MONITOR

A GiM CIU unit with I/O sensor board integrated for Grundfos iSOLUTIONS MONITOR with variants for CIM 280-EU Grundfos iSOLUTIONS Cloud/CIM 280-US Grundfos iSOLUTIONS Cloud and CIM 550. Has built-in Modbus RTU interface.

E-Box

An external communication unit for small DDA dosing pumps.

- E-Box 150 PROFIBUS DP with built-in CIM 150
- E-Box 200 Modbus RTU with built-in CIM 200
- E-Box 500 Ethernet with built-in CIM 500 for support of PROFINET IO, Modbus TCP, EtherNet/IP

CIM/CIU interface products mapped to protocols

	MAGNA3-D Twin pump 2)	MAGNA 3	TPED 11-22 kW Twin pump	Twin pump TPED Model H/I/J 1)	E-pump MGE model H/I/J + 11-22 kW	CIU + TPE 22-55 kW	Hydro MPC (CU 352)	Multi-E MGE 11-22 kW model G/F	Multi-E Model H/I/J 1)	MP 204	Dedicated Controls (CU 362)	Wastewater AUTOADAPT 1-4 pumps	Level Controller LC 2x1, LC 2x2	DDA dosing 3)	Grundfos iSOLUTIONS MONITOR
GENibus			built-in	built-in	built-in	built-in		built-in	built-in	built-in				built-in	built-in
LONWorks															
PROFIBUS DP															
PROFINET IO															
Modbus TCP															
Modbus RTU															built-in
EtherNet/IP															
BACnet MS/TP															
BACnet IP															
Grundfos iSOLUTIONS Cloud (GIC 5)*)															
Cellular data connection for SCADA and SMS 4)															
Radio to Grundfos GO Remote	built-in	built-in		built-in	built-in				built-in						

Note: To create a CIU xxx solution, you need to order a CIU 900 + the required CIM xxx interface and mount the CIM xxx interface into CIU 900. This is the same for a CIU 901, CIU 902, CIU 903. *EU/US version only

- 1) A second CIM module can optionally be mounted in pump no. 2 for redundancy
- 2) MAGNA3-D model D requires 1x CIM in master head, MAGNA3-D models A-C require a CIM in each head (for LONWorks 2x CIM 100)
- 3) Small DDA uses the E-Box, whereas DDA XL uses the CIU unit plus the appropriate CIM module
- 4) CIM 260 3G/4G cellular is only available in regional version for EU, as it requires an external 4G/3G/2G antenna for EU with PN 99518079 and a SIM data subscription card.
- 5) CIM 280-EU Grundfos iSOLUTIONS Cloud requires an external 4G/3G/2G antenna for EU with PN 99518079; CIM 280-US Grundfos iSOLUTIONS Cloud requires a related US 3G/4G antenna PN 98851149 and a Mounting bracket for USA antenna PN 99606614. Both CIM will be delivered with a eUICC SIM card in the package. Reach out to Grundfos to verify that your product is supported from the cloud, as this depends on the available cloud driver.

Note: Hydro Multi-B is supported by CIM 050 GENibus, CIM 110 LON, CIM 200 Modbus RTU, CIM 300 BACnet MS/TP, CIM 500 (Modbus TCP, BACnet IP), CIM 260 3G/4G cellular, CIM 280-EU Grundfos iSOLUTIONS Cloud/CIM 280-US Grundfos iSOLUTIONS Cloud 5).
 Note: E-pumps are CRE/CRNE/CRIE, MTRE, CME, TPE2/TPE3, NBE/NKE.

BACnet IP, BACnet MS/TP, LONWorks - For pumps and boosters

General CIU 900 data

Supply voltage	24-240 VAC/VDC, -10 %/+15 %
Frequency	0-60 Hz
Power consumption	Max. 11 W
Cable size	IEC: 0.2-4 mm ² , UL: 24-12 AWG
Enclosure class	IP 54, according to IEC 60529
Cable entry	6 x M16 Ø4 - Ø10
Operating temperatures	-20 °C to +45 °C (-4 °F to +113 °F)
Storage temperatures	-20 °C to +60 °C (-4 °F to +140 °F)
Dimensions (H/W/D)	182 x 108 x 82 mm

GENibus Communication

Protocol	GENibus
Transceiver	RS-485
Recommended cable type	Screened, double twisted-pair
Maximum cable length	1200 m/4000 ft

CIM 500 BACnet IP Communication

Protocol	BACnet IP (set rotary switch to position 2)
Transmission speeds	10/100 Mbit/s
Ports	2x RJ45
IP settings	built-in webserver

CIM 300 BACnet MS/TP Communication

Protocol	BACnet MS/TP (Master)
Transceiver	RS-485
Transmission speeds	9.6, 19.2, 38.4, 76.8 kbits/s
BACnet master address	0-127

CIM 100 LON for pump/CIM 110 LON for booster & twin pump communication

Protocol	LONtalk
Transceiver	FTT-10
Transmission speed	78 kbits/s

Example with BACnet IP



Data points

BACnet IP, BACnet MS/TP, LONWorks

	MAGNA/UEPE	MAGNA3	E-pumps <11 kW E-pumps model J	CUE E-pumps 11-22 kW	Multi-E, TPED	Hydro MPC/ Control MPC	Hydro Multi-B
s = if sensor installed							
s* = available with sensor or TPE 2000 and TPE3							
¹ differential or absolute, depends on sensor							
² Not standard for Control MPC							
G = only for MGE model G or later							
H = only for MGE model H or later							

Control							
Operating Mode	•	•	•	•	•	•	•
Setpoint	•	•	•	•	•	•	•
Control Mode	•	•	•	•	H	•	•
Relay Control					H		
Tank filling status							•

Status							
Operating Mode status	•	•	•	•	•	•	•
Control Mode Status	•	•	•	•	•	•	•
Feedback	•	•	•	•	•	•	•
Alarm/warning information	•	•	•	•	•	•	•
Bearing Service Information			G	•			
Tank filling control							•

Measured Data							
Power/Energy Consumption	•	•	•	•	•	•	•
Pressure (Head) ¹	•	•	s*	s*	•	• ²	s
Flow	•	•	s*	s*	H+s	• ²	
Relative Performance	•	•	•	•	•	•	•
Speed and Frequency	•	•	•	•			
Digital Input/Output	•	•	•	•	•	•	•
Motor Current							
Motor Voltage			G only	•			
Remote Flow			s	G+s	s	H+s	
Inlet Pressure ¹				G+s	s	H+s	s
Remote Pressure ¹			s	G+s	s	H+s	s
Level				s	s	H+s	s
Motor Temperature				G+s	s		
Remote Temperature				s	s	H+s	s
Pump Liquid Temperature	•	•		G+s	s	H+s	
Bearing Temperatures				H+s	s		
Auxiliary Sensor Input				s	s	H+s	
Operation Time (Run Time)	•	•	•	•	•	•	•
Total on time	•	•	•	•	•	•	•
Number Of Starts			•	•	•	•	•
Volume				H+s	CUE + s		
Ambient Temperature				H+s		H+s	s
Inlet and Outlet Temperatures							s
Heat energy meter	•	•		H			
Outlet Pressure ¹				H+s		H+s	s
Feed Tank Level				H+s		H+s	s

Subpump Data							
Alarm/Status information					•	•	•
Operation Time (Run Time)					•	•	•
Speed					H	•	•
Line current/power consumption					H	•	•
Motor temperature					H	•	•
Number of starts					H	•	•
Control pump: force to stop/auto						•	•

Note: E-pumps = CRE/CRNE/CRIE, MTRE, CME, TPE2/TPE3, NBE/NKE.
 Note: TPED twin pump model F or G in range 3-22 kW needs always 2 CIU modules.
 Note: MAGNA3-D twinpump model D requires 1x CIM interface installed in master head.
 For LONWorks 1x CIM 110 installed in master head.

BACnet IP, BACnet MS/TP - For water utility products

General CIU 900	
Supply voltage	24-240 VAC/VDC, -10 %/+15 %
Frequency	0-60 Hz
Power consumption	Max. 11 W
Cable size	IEC: 0.2-4 mm ² , UL: 24-12 AWG
Enclosure class	IP 54, according to IEC 60529
Cable entry	6 x M16 Ø4 - Ø10
Operating temperatures	-20 °C to +45 °C (-4 °F to +113 °F)
Storage temperatures	-20 °C to +60 °C (-4 °F to +140 °F)
Dimensions (H/W/D)	182 x 108 x 82 mm

GENIbus Communication	
Protocol	GENIbus
Transceiver	RS-485
Recommended cable type	Screened, double twisted-pair
Maximum cable length	1200 m/4000 ft

CIM 500 BACnet IP Communication	
Protocol	BACnet IP (set rotary switch to position 2)
Transmission speeds	10/100 Mbits/s
Ports	2x RJ45
IP settings	built-in webserver

CIM 300 BACnet MS/TP Communication	
Protocol	BACnet MS/TP (Master)
Transceiver	RS-485
Transmission speeds	9.6, 19.2, 38.4, 76.8 kbits/s
BACnet master address	0-127

Example with CIM 500

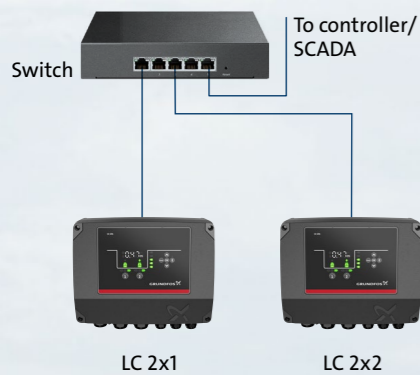

Data points		
BACnet IP, BACnet MS/TP		
	LC 2x1	LC 2x2
System Control		
Reset alarm	•	•
Interlock pit		
Custom relay control (On/Off/Pulse)		
Pump Control		
Pumps On/Off/Auto	•	•
Pump down		
Configuration		
Set system and pumps control levels	•	•
System status		
System operation mode	•	•
Active alarms/warnings	•	•
System mode (single/multi)		
Status/function of float switches	•	•
Presence of sensors	•	•
Real time clock (read and set)		
System control source (Manual/Auto)	•	•
System and pumps control levels	•	•
Water level	•	•
Water level max		
In/out flow		
Power/Energy consumption	•	•
Specific energy		
Volume		
Overflow volume/time/counter		
Operation time	•	•
Operation time for simultaneous pumps		
Mixer average starts per hours		
3 x user defined sensor inputs	•	•
Float switches	•	•
Digital inputs	•	•
8 x I/O logic outputs		
Digital Outputs	•	•
Pump status		
Presence of pump	•	•
Pump enabled/disabled		
Running/Stopped	•	•
Active alarms/warnings	•	•
Auxiliary equipment status		
Control source	•	•
Operation time	• ¹	• ¹
Starts counter (total/average)	• ¹	• ¹
Latest continuous operation time		
Max continuous operation time		
Time to service	•	•
Pulse Flow meter		
Current (actual/latest)	• ²	• ²
Voltage/frequency		
Current asymmetry		
Power/Power factor/Energy consumption	• ³	• ³
Motor temperature		
Insulation		
Water in oil		

1) Available as 3 datapoints for yesterday, today and total
For information related to Grundfos iSOLUTIONS Cloud please contact Grundfos
2) LC 2X1 and LC 2X2 only have actual current
3) LC 2X1 and LC 2X2 do not measure power factor

PROFINET IO, Modbus TCP, EtherNet/IP, PROFIBUS DP, Modbus RTU - For pumps and boosters

General CIU 900, CIU 901, CIU 902	
Supply voltage	24-240 VAC/VDC, -10 %/+15 %
Frequency	0-60 Hz
Power consumption	Max. 11 W
Cable size	IEC: 0.2-4 mm ² , UL: 24-12 AWG
Enclosure class	IP 54, according to IEC 60529
Cable entry	6 x M16 Ø4 - Ø10
Operating temperatures	-20 °C to +45 °C (-4 °F to +113 °F)
Storage temperatures	-20 °C to +60 °C (-4 °F to +140 °F)
Dimensions (H/W/D)	182 x 108 x 82 mm

CIU 902 is used together with wastewater AUTOADAPT pumps

GENIbus Communication	
Protocol	GENIbus
Transceiver	RS-485
Recommended cable type	Screened, double twisted-pair
Maximum cable length	1200 m/4000 ft

CIM 500 PROFINET IO, Modbus TCP, EtherNet/IP Communication	
Protocol	PROFINET IO (rotary switch position 0) Modbus TCP (rotary switch position 1) EtherNet/IP (rotary switch position 3)
Transmission speeds	10/100 Mbits/s
Ports	2x RJ45
Conformance class	B

CIM 200 Modbus RTU Communication	
Protocol	Modbus RTU
Transceiver	RS-485
Transmission speeds	1.2, 2.4, 4.8, 9.6, 19.2, 38.4 kbits/s
Parity settings	Even, Odd or No parity
Stop bits	1 or 2
Modbus Slave address	1-247, set via rotary switches

CIM 150 PROFIBUS DP Communication	
Protocol	PROFIBUS DP
Transceiver	RS-485
Implementation class	DP-V0
Transmission speeds	9600 bits/s to 12 Mbit/s
Slave address	1-126, set via rotary switches

Example with CIM 500

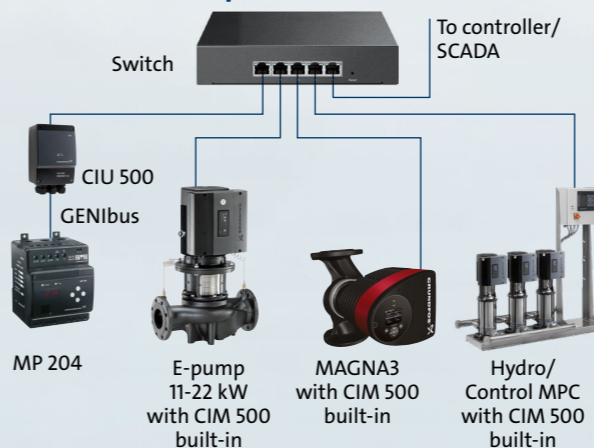

Data points							
PROFINET IO, Modbus TCP, EtherNet/IP, PROFIBUS DP, Modbus RTU							
	MAGNA/UEPE	MAGNA3	E-pumps <11 kW E-pumps model J	E-pumps 11-22 kW CUE	Multi-E, TPED	Hydro MPC/ Control MPC	Hydro Multi-B MP 204
s = if sensor installed s* = available with sensor or TPE 2000 and TPE3 1 differential or absolute, depends on sensor 2 Not standard for Control MPC 3 Not supported for all pump variants H = only MGE model H or later G = only MGE model G or later							
Control							
Operating Mode	•	•	•	•	•	•	•
Setpoint	•	•	•	•	•	•	•
Control Mode	•	•	•	•	H	•	•
Relay Control			•	•			
Tank filling control							•
Status							
Operating Mode Status	•	•	•	•	•	•	•
Control Mode Status	•	•	•	•	•	•	•
Feedback	•	•	•	•	•	•	•
Alarm and warning information	•	•	•	•	•	•	•
Bearing Service information			H	•			
Tank filling status information							•
Measured Data							
Power/Energy Consumption	•	•	•	•	•	•	•
Pressure (Head) ¹	•	•	s*	s*	•	• ²	s
Flow	•	•	s*	s*	H+s	• ²	
Relative Performance	•	•	•	•	•	•	•
Speed and Frequency	•	•	•	•	•	•	•
Digital Input/Output	•	•	•	•	•	•	•
Motor Current			•	•			•
DC Link Voltage	•	•	•	•			
Motor Voltage			G only	•			•
Remote Flow		s	G+s	s	H+s		
Inlet Pressure ¹			G+s	s	H+s	s	s
Remote Pressure ¹		s	G+s	s	H+s	s	
Level			s	s	H+s	s	s
Motor Temperature			G+s	s			s
Remote Temperature		s	s	s	H+s	s	
Pump Liquid Temperature	•	•	G+s	s			
Bearing Temperatures			H+s	s			
Auxiliary Sensor Input			s	s	H+s		
Operation Time (Run Time)	•	•	•	•	•	•	•
Total on time	•	•	•	•	•	•	•
Torque (N/A on 1-phased motors)			•	•			
Number Of Starts	•	•	•	•			
Volume			H+s	CUE + s			
Ambient Temperature			H+s		H+s	s	
Inlet and Outlet Temperatures						s	
Heat energy meter	•		H				
Outlet Pressure ¹			H+s		H+s	• ²	s
Feed Tank Level			H+s		H+s	s	s
Phase Voltages							•
Line Voltages/Currents/Frequency							•
Start/Run Capacitor							•
Voltages Angles + Cos phi							•
Insulation resistance							•
Starts/h and auto restarts/24h							•
Subpump Data (for each sub pump in the system)							
Status information					•	•	•
Alarm information					•	•	•
Operation Time (Run Time)					•	•	•
Speed					H	•	•
Line current/power consumption					H	•	•
Motor temperature					H	•	•
Number of starts					H	•	•
Control pump: forc to stop/auto						•	•

Note: E-pumps = CRE/CRNE/CME, MTR, CHIE, TPE2/TPE3, NBE/NKE
Note: For DDA dosing pumps please view to DDA related pages
Note: TPED twin pump model F or G in range 3-22 kW needs always 2 CIU modules
Note: MAGNA3-D twin pump model D only requires 1x CIM interface installed in master head
Note: Hydro Multi-B only supported by Modbus RTU and Modbus TCP

PROFINET IO, Modbus TCP, EtherNet/IP, PROFIBUS DP, Modbus RTU

- For water utility products

General CIU 900, CIU 901, CIU 902

Supply voltage	24-240 VAC/VDC, -10 %/+15 %
Frequency	0-60 Hz
Power consumption	Max. 11 W
Cable size	IEC: 0.2-4 mm ² , UL: 24-12 AWG
Enclosure class	IP 54, according to IEC 60529
Cable entry	6 x M16 Ø4 - Ø10
Operating temperatures	-20 °C to +45 °C (-4 °F to +113 °F)
Storage temperatures	-20 °C to +60 °C (-4 °F to +140 °F)
Dimensions (H/W/D)	182 x 108 x 82 mm

CIU 902 is used together with wastewater AUTOADAPT pumps

GENibus Communication

Protocol	GENibus
Transceiver	RS-485
Recommended cable type	Screened, double twisted-pair
Maximum cable length	1200 m/4000 ft

CIM 500 PROFINET IO, Modbus TCP, EtherNet/IP Communication

Protocol	PROFINET IO (rotary switch position 0) Modbus TCP (rotary switch position 1) EtherNet/IP (rotary switch position 3)
Transmission speeds	10/100 Mbits/s
Ports	2x RJ45
Conformance class	B

CIM 200 Modbus RTU Communication

Protocol	Modbus RTU
Transceiver	RS-485
Transmission speeds	1.2, 2.4, 4.8, 9.6, 19.2, 38.4 kbits/s
Parity settings	Even, Odd or No parity
Stop bits	1 or 2
Modbus Slave address	1-247, set via rotary switches

CIM 150 PROFIBUS DP Communication

Protocol	PROFIBUS DP
Transceiver	RS-485
Implementation class	DP-V0
Transmission speeds	9600 bits/s to 12 Mbit/s
Slave address	1-126, set via rotary switches

Example with CIM 500

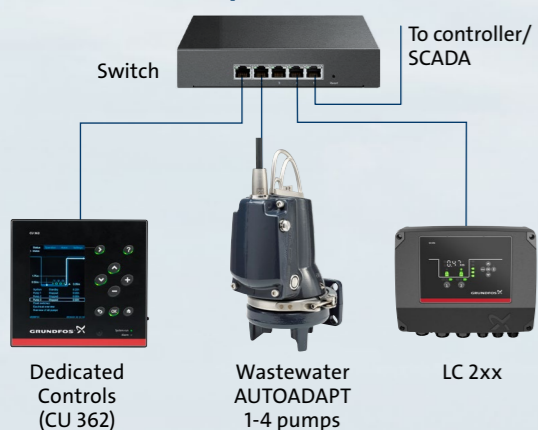

Data points

PROFINET IO, Modbus TCP, EtherNet/IP, PROFIBUS DP, Modbus RTU	LC 2x1 / LC 2x2	Dedicated Controls CU 362	Wastewater AUTOADAPT CIU xx2*
System Control			
Reset alarm	•	•	•
Interlock pit		•	
Custom relay control (On/Off/Pulse)		•	
Pump Control			
Pumps On/Off/Auto	•	•	•
Pump down			•
Configuration			
Set system and pumps control levels	•	•	•
System status			
System operation mode	•	•	•
Active alarms/warnings	•	•	•
Pit mode (single/multi)			•
Status/function of float switches	•	•	
Presence of sensors	•	•	
Real time clock (read and set)	•	•	
System control source (Manual/Auto)	•	•	•
System and pumps control levels	•	•	•
Water level	•	•	•
Water level max			•
In/ out flow or pulse flow meter	• ⁵	•	
Power/Energy consumption	•	• ¹	• ¹
Specific energy		•	
Volume		• ¹	
Overflow volume/time/counter		• ¹	
Operation time	•	•	•
Operation time for simultaneous pumps		• ¹	•
Mixer average starts per hours		•	
3 x user defined sensor inputs	•	•	
Float switches	•	•	
Digital inputs	•	•	•
8 x I/O logic outputs		•	
Digital Outputs	•		
Pump status			
Presence of pump	•	•	•
Pump enabled/disabled		•	
Running/Stopped	•	•	•
Active alarms/warnings	•	•	•
Auxiliary equipment status		•	
Control source	•	•	
Operation time	• ¹	• ¹	• ¹
Starts counter (total/average)	• ¹	• ¹	• ¹
Latest continuous operation time		•	
Max continuous operation time		•	
Time to service	•	•	
Flow (actual/latest)		•	
Current (actual/latest)	• ²	•	•
Voltage/frequency		•	
Current asymmetry		•	
Power/Power factor/Energy consumption	• ³	•	• ³
Motor temperature		•	•
Insulation		•	
Water in oil		•	
Special (Modbus only)			
Hour log (latest 72h of main pit/pump values)		•	
Event log (50 latest alarms/warnings w. time stamp)	• ⁴	•	
User defined data log (40000 registers)	• ⁴	•	

1) Available as 3 datapoints for yesterday, today and total
For information related to Grundfos iSOLUTIONS Cloud please contact Grundfos
2) LC 2X1 and LC 2X2 only have actual current
3) LC 2X1, LC 2X2 and AUTOADAPT do not measure power factor
4) LC 2X1 and LC 2X2 only have 40 logs
5) LC 2X2 only

*To create a CIU 152, you order CIU 902 + CIM 150. To create a CIU 202, you order CIU 902 + CIM 200. To create a CIU 502, you order CIU 902 + CIM 500

Cellular data connection to SCADA or operation via SMS

- For pumps and boosters

General CIU 900, CIU 901, CIU 902, CIU 903

Supply voltage	24-240 VAC/VDC, -10 %/+15 %
Frequency	0-60 Hz
Power consumption	Max. 11 W
Cable size	IEC: 0.2-4 mm ² , UL: 24-12 AWG
Enclosure class	IP 54, according to IEC 60529
Cable entry	6 x M16 Ø4 - Ø10
Operating temperatures	-20 °C to +45 °C (-4 °F to +113 °F)
Storage temperatures	-20 °C to +45 °C (-4 °F to +113 °F)
Dimensions (H/W/D)	182 x 108 x 82 mm

CIU 902 is used together with wastewater AUTOADAPT pumps
CIU 903 is used together with MGEFlex and SQFlex pumps, and only with CIM 280 for Grundfos iSOLUTIONS Cloud

GENibus communication

Protocol	GENibus
Transceiver	RS-485
Recommended cable type	Screened, double twisted-pair
Maximum cable length	1200 m/4000 ft

3G/4G cellular communication

Protocol	SMS
	Data connection (Modbus TCP)
3G/4G antenna	Available as an option
Battery	Available as an option
SIM card	To be supplied by user/installer

SMS features

Read product status	E.g. pressure, power, temperature etc. (depends on product type) Request active alarms/warnings Request I/O signal status
Read network status	E.g. signal level, battery status, cellular status and data statistics.
Self-triggered messages	Alarm/warning event messages Heart beat messages
Control	Set operating mode (e.g. Start/stop) Set control mode (e.g. constant pressure) Set setpoint Reset alarms Set analog output
Configuration	SMS access control via PIN code Configuration of SMS functions Configuration of cellular connection
CIU 901 I/O board	2 configurable inputs (digital or analog 0/4-20 mA, 0-10 V) 1 Relay output (230 V, 2 A) 1 Analog signal input (0-10 V) 1 Temperature input (Pt100/Pt1000, 2-wire) 2 digital inputs

Data points

CIM 260 3G/4G cellular for Europe	MAGNA/UEPE	MAGNA3	E-pumps <11 kW E-pumps model J	E-pumps 11-22 kW CUE	Multi-E, TPED	Hydro MPC/Control MPC	Hydro Multi-B	MP 204
Control								
Operating Mode	•	•	•	•	•	•	•	•
Setpoint	•	•	•	•	•	•	•	•
Control Mode	•	•	•	•	H	•		
Relay Control			•	•				
Tank filling control							•	
Status								
Operating Mode status	•	•	•	•	•	•	•	•
Control Mode status	•	•	•	•	•	•	•	•
Feedback	•	•	•	•	•	•	•	•
Alarm/warning information	•	•	•	•	•	•	•	•
Bearing Service Information			G	•				
Tank filling status information							•	
Measured Data								
Power/Energy Consumption	•	•	•	•	•	•	•	•
Pressure (Head) ¹	•	•	s*	s*	•	• ²	s	
Flow	•	•	s*	s*	H+s	• ²		
Relative Performance	•	•	•	•	•	•	•	
Speed and Frequency	•	•	•	•				
Digital Input/Output			•	•	•	•	•	
Motor Current			•	•	•			•
DC Link Voltage			•	•				
Motor Voltage			G only	•				•
Remote Flow		s	G+s	s	H+s			
Inlet Pressure ¹			G+s	s	H+s	s	s	
Remote Pressure ¹		s	G+s	s	H+s	s		
Level			s	s	H+s	s	s	
Motor Temperature			G+s	s				s
Remote Temperature		s	s	s	H+s	s		
Pump Liquid Temperature	•	•	G+s	s				
Bearing Temperatures			H+s	s				
Auxiliary Sensor Input			s	s	H+s			
Operation Time (Run Time)	•	•	•	•	•	•	•	•
Total on time	•	•	•	•	•	•	•	•
Number Of Starts		•	•	•				•
Volume			H+s	CUE + s				
Ambient Temperature			H+s		H+s	s		
Inlet and Outlet Temperatures						s		
Heat energy meter	•	H						
Outlet Pressure ¹			H+s		H+s	• ²	s	
Feed Tank Level			H+s		H+s	s	s	
Phase Voltages								•
Line Voltages/Currents/Frequency								•
Start/Run Capacitor								•
Voltage Angles + Cos phi								•
Insulation resistance								•
Starts/h and auto restarts/24h								•
Subpump Data								
Alarm/Status information					•	•	•	
Operation Time (Run Time)					•	•	•	
Speed					H	•	•	
Line current/power consumption					H	•	•	
Motor temperature						•	•	
Number of starts						•	•	
Control pump: force to stop/auto						•	•	

Note: E-pumps = CRE/CRNE/CRIE, MTRE, CME, TPE2/TPE3, NBE/NKE.
Note: TPED twin pump model F or G in range 3-22 kW needs always 2 CIU modules.
Note: MAGNA3-D twin pump model D requires 1x CIM interface installed in master head.

Cellular data connection to SCADA or operation via SMS - For water utility products

General CIU 900, CIU 901, CIU 902, CIU 903

Supply voltage	24-240 VAC/VDC, -10 %/+15 %
Frequency	0-60 Hz
Power consumption	Max. 11 W
Cable size	IEC: 0.2-4 mm ² , UL: 24-12 AWG
Enclosure class	IP 54, according to IEC 60529
Cable entry	6 x M16 Ø4 - Ø10
Operation temperatures	-20 °C to +45 °C (-4 °F to +113 °F)
Storage temperatures	-20 °C to +60 °C (-4 °F to +140 °F)
Dimensions (H/W/D)	182 x 108 x 82 mm

CIU 902 is used together with wastewater AUTOADAPT pumps
CIU 903 is used together with MGEFlex and SQFlex pumps, and only with CIM 280 for Grundfos iSOLUTIONS Cloud

GENIbus communication

Protocol	GENIbus
Transceiver	RS-485
Recommended cable type	Screened, double twisted-pair
Maximum cable length	1200 m/4000 ft

Cellular communication

Protocol	SMS
	Cellular data connection (Modbus TCP)
3G/4G antenna	Available as an option
Battery	Available as an option
SIM card	To be supplied by user/installer

SMS features

Read product status	E.g. pressure, power, temperature etc. (depends on product type) Request active alarms/warnings Request I/O signal status
Read network status	E.g. signal level, battery status, cellular status and data statistics.
Self-triggered messages	Alarm/warning event messages Heart beat messages
Control	Pit interlocking Reset alarms
Configuration	SMS access control via PIN code Configuration of SMS functions Configuration of cellular connection
I/O board	2 configurable inputs (digital or analog 0/4-20 mA, 0-10 V) 1 Relay output (230 V, 2 A) 1 Analog signal output (0-10 V) 1 Temperature input (Pt100/Pt1000, 2-wire) 2 digital inputs

Data points

CIM 260 3G/4G cellular for Europe			
	LC 2x1 / LC 2x2	Dedicated Controls CU 362	Wastewater AUTOADAPT CIU 262 ¹
System Control			
Reset alarm	•	•	•
Interlock pit		•	
Custom relay control (On/Off/Pulse)		•	
Pump Control			
Pumps On/Off/Auto	•	•	•
Pump down			•
Configuration			
Set system and pumps control levels	•	•	•
System status			
System operation mode	•	•	•
Active alarms/warnings	•	•	•
Pit mode (single/multi)			•
Status/function of float switches	•	•	
Presence of sensors	•	•	
Real time clock (read and set)	•	•	
System control source (Manual/Auto)	•	•	•
System and pumps control levels	•	•	•
Water level	•	•	•
Water level max			•
In/ out flow or pulse meter	• ⁵	•	
Power/Energy consumption	•	• ¹	• ¹
Specific energy		•	
Volume		• ¹	
Overflow volume/time/counter		• ¹	
Operation time	•	•	•
Operation time for simultaneous pumps		• ¹	•
Mixer average starts per hours		•	
3 x user defined sensor inputs	•	•	
Float switches	•	•	
Digital inputs	•	•	•
8 x I/O logic outputs		•	
Digital Outputs	•		
Pump status			
Presence of pump	•	•	•
Pump enabled/disabled		•	
Running/Stopped	•	•	•
Active alarms/warnings	•	•	•
Auxiliary equipment status		•	
Control source	•	•	
Operation time	• ¹	• ¹	• ¹
Starts counter (total/average)	• ¹	• ¹	• ¹
Latest continuous operation time		•	
Max continuous operation time			•
Time to service	•	•	
Flow (actual/latest)		•	
Current (actual/latest)	• ²	•	•
Voltage/frequency		•	
Current asymmetry		•	
Power/Power factor/Energy consumption	• ³	•	• ³
Motor temperature		•	•
Insulation		•	
Water in oil		•	
Special (Modbus only)			
Hour log (latest 72h of main pit/pump values)		•	
Event log (50 latest alarms/warnings w. time stamp)	• ⁴	•	
User defined data log (40000 registers)	• ⁴	•	

1) Available as 3 datapoints for yesterday, today and total
For information related to Modbus TCP, PROFINET or Grundfos iSOLUTIONS Cloud please contact Grundfos
2) LC 2X1 and LC 2X2 only have actual current
3) LC 2X1, LC 2X2 and AUTOADAPT do not measure power factor
4) LC 2X1 and LC 2X2 only have 40 logs
5) LC 2X2 only
* To create a CIU 262, you order a CIU 902 + CIM 260

DDA E-Box versions - For small Grundfos digital dosing pumps

The small DDA is mounted directly on top of the E-Box, and the bus cable included with the E-Box is connected between the small DDA and E-Box.
The small DDA can also use the CIU unit and in that case the GENIbus cable is ordered separately. The DDA XL always uses the CIU unit solution.

PROFIBUS -DP Communication (E-Box 150)

Protocol	PROFIBUS DP
Implementation Class	DP-V0
Transmission speeds	9600 bits/s to 12 Mbits/s
Slave address	1-126, set via DDA display

Modbus RTU Communication (E-Box 200)

Protocol	Modbus RTU
Transceiver	RS-485
Transmission speeds	1.2, 2.4, 4.8, 9.6, 19.2, 38.4 kbits/s
Parity settings	Even, Odd or No parity
Stop bits	1 or 2
Slave address	1-247, set via DDA display

CIM 500 PROFINET IO, Modbus TCP, EtherNet/IP Communication

Protocol	PROFINET IO (rotary switch position 0) Modbus TCP (rotary switch position 1) EtherNet/IP (rotary switch position 3)
Transmission speed	10/100 Mbits/s
Ports	2 x RJ45
PROFINET conformance class	B

Data points

DDA E-Box 150, E-Box 200 or E-Box 500			
	Control variant FCM	Control variant FC	Control variant AR
Control			
Operating Mode (Start, Stop, Service, Calibrating), Functions (Slow mode, Viscosity selection), Deaerating mode	•	•	•
Function Enable/Disable (AutoDeaerating, FlowMonitor, Profibus Watchdog, AutoFlow, PulseMemory)	•	•	•
Pulse signal from bus	•	•	•
Reset Fault and Volume Counter	•	•	•
Control Mode (Manual, Pulse, Analogue, Timer, Batch)	•	•	•
Set Manual Flow Setpoint	•	•	•
Set Pulse Volume	•	•	•
Set Batch Volume	•	•	•
Set Batch Dosing Time	•	•	•
Set Flow Monitor Pressure Alarm Limit	•	•	•
Relay Control of Relay 1 and 2	•	•	•
Set Analog Output	•	•	•
Set Date & Time	•	•	•
Status			
Operating Mode Status	•	•	•
Control Mode Status	•	•	•
Alarm/warning/dosing (running) Status	•	•	•
Actual Manual Flow Setpoint	•	•	•
Actual Pulse Volume Setting	•	•	•
Actual Batch Dosing Volume Setting	•	•	•
Actual Batch Dosing Time Setting	•	•	•
Actual Flow Monitor Pressure Alarm Limit Setting	•	•	•
Control Source (HMI, External, Bus)	•	•	•
Fault & Warning Code	•	•	•
Warning Status Bits	•	•	•
Actual Date & Time	•	•	•
Max Dosing Pressure	•	•	•
Max Dosing Capacity	•	•	•
Resulting Dosing Capacity Setpoint	•	•	•
Remaining Dosing Volume	•	•	•
Total Dosed Volume	•	•	•
Volume Trip Counter	•	•	•
Actual Analog Output Signal	•	•	•
Digital Outputs	•	•	•
Number Of Starts	•	•	•
Run Time	•	•	•
Total On Time	•	•	•
Stroke Counter	•	•	•
Time To Next Dosing	•	•	•
Measured Data			
Digital Inputs	•	•	•
Analog Input Signal	•	•	•
Pulse Input Frequency	•	•	•
Measured Dosing Capacity	•		
Measured Dosing Pressure	•	•	

Network example with CIM 500 Ethernet

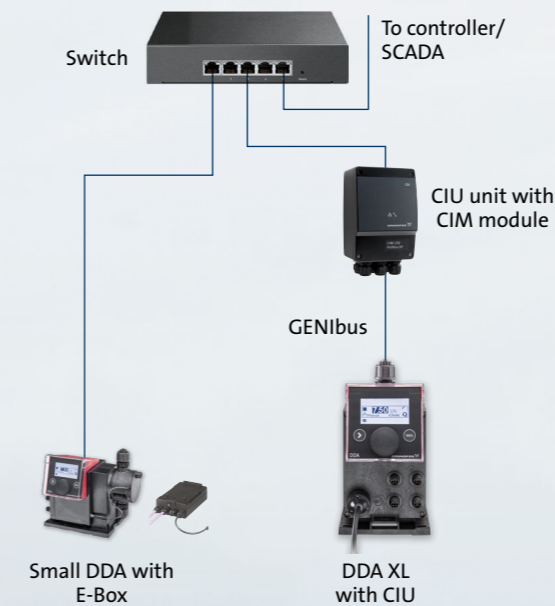

Grundfos iSOLUTIONS MONITOR

Grundfos iSOLUTIONS MONITOR is a condition monitoring system which reduces the risk of unexpected downtime and maintenance, offering optional monitoring of both process and operational data.

Grundfos iSOLUTIONS MONITOR is a setup that monitors your pumps and pump systems for the most common issues. Compared to traditional condition monitoring solutions, it provides you with instant conclusions that you can act on right away. Grundfos service technicians are always available to remotely monitor and help you optimise your system.

Grundfos iSOLUTIONS MONITOR keeps track of a variety of common issues including motor bearing damage, dry-run, cavitation, unbalance, water hammer and liquid temperature.

These insights help you make better decisions in terms of maintenance or system optimisation. Or, you can get in touch with Grundfos to get advice from experienced service technicians. When connected to MGE or CUE, you can also monitor operational data including power consumption, speed and set points. You can even attach sensors to read data such as inlet pressure, discharge pressure, flow and extra temperature.

Grundfos iSOLUTIONS MONITOR includes a CIU unit mounted beside or on the pump, a web interface and a Grundfos GO interface to follow your installations remotely.

It can also be integrated via Modbus RTU with your SCADA/BMS system and simultaneously be connected to the Grundfos iSOLUTIONS Cloud.

TRACK YOUR PUMP INSTALLATIONS FROM ANYWHERE

Quick overview of your facility

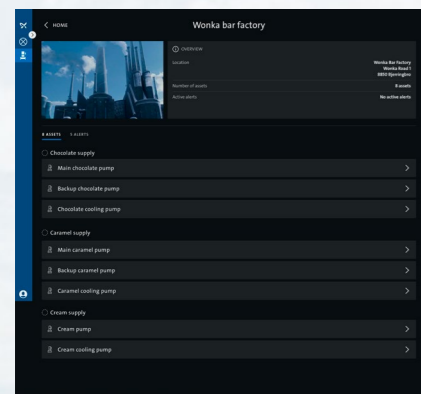

Everything you need to know on one page

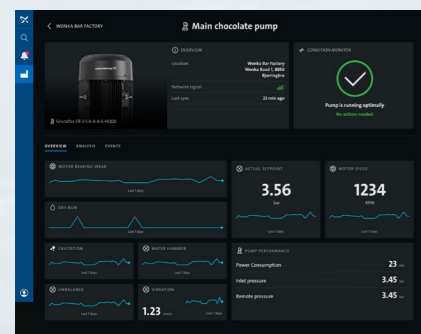

Alarm and warning description

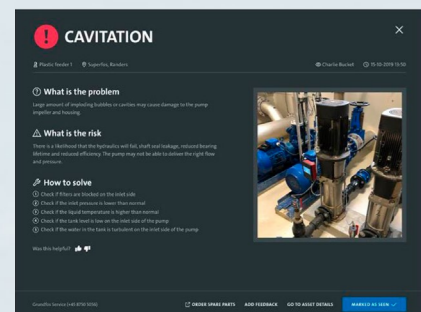

Product numbers of Grundfos CIM/CIU communication interfaces

Interface name	Product no.	Comment
CIM 040 GENI TTL	98415941	For CU 354 DDD
CIM 050 GENIbus	96824631	
CIM 060 GlowPan	98778356	Require 98778357 Antenna kit for CIM 060
CIM 100 LON	96824797	LONWorks for pumps
CIM 110 LON	96824798	LONWorks for boosters and twin pumps. Install CIM in master head in twin pumps and Multi-E
CIM 150 PROFIBUS DP	96824793	
E-Box 150 PROFIBUS DP	97513994	For small DDA pumps
CIM 200 Modbus RTU	96824796	
E-Box 200 Modbus RTU	98563350	For small DDA pumps
CIM 260-EU 3G/4G cellular	99439302	For European frequency bands. Requires PN 99518079 antenna kit 3G/4G SIM card
CIM 280-EU Grundfos iSOLUTIONS Cloud (including eUICC SIM card) Cellular 3G/4G 1)	99895383	For European frequency bands. Requires PN 99518079 antenna kit. Includes eUICC SIM card in package. Ask Grundfos which products are supported from the cloud.
CIM 280-US Grundfos iSOLUTIONS Cloud (including eUICC SIM card) Cellular 3G/4G 1)	99895386	For North America frequency bands. Requires PN 98851149 US antenna + mounting bracket: PN 99606614. Includes eUICC SIM card in package. Ask Grundfos which products are supported from the cloud.
CIM 280-EU GDP for Grundfos iSOLUTIONS MONITOR retrofit only	99837175	For European frequency bands. Requires 99518079 antenna kit. 3G/4G SIM card must have additional international PDU SMS roaming active
CIM 280-US GDP for Grundfos iSOLUTIONS MONITOR retrofit only	99837177	For North America frequency bands. Requires PN 98851149 US antenna +mounting bracket: PN 99606614. 3G/4G SIM card must have additional international PDU SMS roaming active
CIM 300 BACnet MS/TP	96893770	
CIM 500 Ethernet 1)	98301408	For Industrial Ethernet protocols PROFINET, Modbus TCP, BACnet IP, EtherNet/IP
CIM 550 Ethernet for Grundfos iSOLUTIONS Cloud 1)	92546689	For wired Internet connectivity to Grundfos iSOLUTIONS Cloud. Ask Grundfos which products are supported from the cloud.
E-Box 500 Ethernet 1)	99171932	For Industrial Ethernet protocols PROFINET, Modbus TCP, EtherNet/IP (small DDA pump only)
CIU 900	99448387	Empty CIU unit. For all CIM modules
CIU 901	99448389	Empty CIU unit with built-in IO board (IO 270) For CIM 200, CIM 260 and CIM 500
CIU 902 AUTOADAPT	97644690	Empty CIU unit with built-in SEG AUTOADAPT board for interface to 1-4 SEG AUTOADAPT pumps. For CIM 150, CIM 200, CIM 260 and CIM 500
CIU 903 MGEflex/SQFlex	98106399	Empty CIU unit with interface for MGE Flex and SQ Flex. Only used for CIM 280
Grundfos iSOLUTIONS MONITOR CIU	For product numbers and subscriptions please reach out to Grundfos	CIU unit with built-in Grundfos iSOLUTIONS MONITOR IO board Variants for CIM 280 GDP, CIM 550 are available. Please refer to Grundfos iSOLUTIONS MONITOR documentation for more information.
CIM 060 antenna kit	98778357	Antenna required only in case of no sight view
Antenna 3G/4G LTE (for Grundfos iSOLUTIONS MONITOR)	99838775	For Grundfos iSOLUTIONS MONITOR in the EU, antenna with 2 m cable and magnetic base
CIM 260/280 puc antenna kit (1.5 m cable)	99518079	For CIM 260 EU/ CIM 280 EU version
CIM 260/280 optional battery	99499908	For CIM 260/ CIM 280 to send a last power failure alarm if power drops
CIM 500 RJ45 Field plug kit	98471752	RJ45 plug assembly kit for flexible Ethernet cable to CIM 500 in CIU 90x (contains 2x RJ45 plug, without cable)
DDA GENIbus cable (3 m)	98589048	For connection to CIU unit
Robustel R3000-L3H, 3G router	99043055	For use in Europe with CIM 550
Robustel R3000-L4L, 4G router	99043057	For use in Europe with CIM 550
3G/4G rod antenna for Robustel Router (5 m cable)	99043061	
External power supply 12 V for Robustel Router	99043052	

Note: To create a CIU xxx version you need to order a CIU 900 + CIM xxx interface, similar for a CIU 901, 902, 903
 1) Contract with Grundfos is required for data hosting in Grundfos iSOLUTIONS Cloud

CIM and CIU Manuals and installation files



Enter the link below to access the CIM and CIU manuals and installation files mentioned in this leaflet.

http://net.grundfos.com/qr/i/CIM_CIU_01

BACnet functional profile manuals

For each product type, a manual exists covering the following:

- CIM 300 BACnet MS/TP
- CIM 500 BACnet IP
- BACnet for MIXIT
- BACnet PICS for CIM 300
- BACnet PICS for CIM 500



LONWorks functional profile manuals

- CIM 100 LON for pumps
- CIM 110 LON for boosters

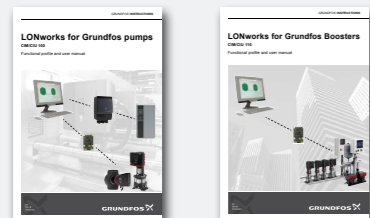

PROFIBUS/PROFINET functional profile manuals

For each product type, a manual exists covering the following:

- CIM 150 PROFIBUS DP
- CIM 500 PROFINET IO



EtherNet/IP functional profile manuals

For each product type, a manual exists covering the following:

- CIM 500 EtherNet/IP



Modbus functional profile manuals

For each product type, a manual exists covering the following:

- CIM 200 Modbus RTU
- CIM 260 Modbus cellular
- CIM 500 Modbus TCP
- Modbus for MIXIT
- Modbus for Grundfos iSOLUTIONS MONITOR

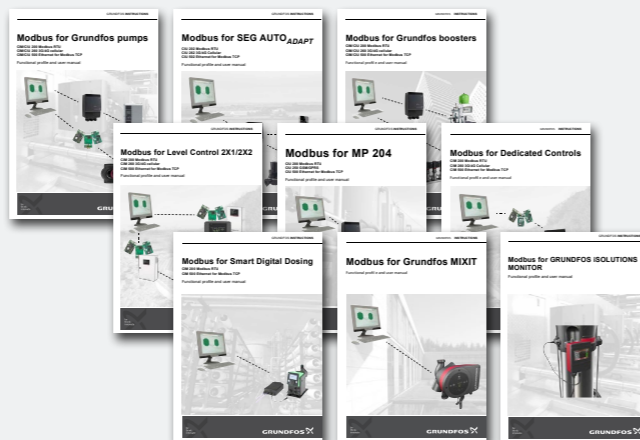

Miscellaneous instructions

- CIM 260 SMS commands
- Multi-purpose IO module in CIU 27x
- Multi-purpose IO module for Grundfos AUTOADAPT pumps
- Multi-purpose IO module for SQ Flex
- Modbus for multi-purpose IO module IO 270
- E-Box 150 Profibus
- E-Box 200 Modbus
- E-Box 500 Ethernet
- CIU - Communication Interface Unit
- Grundfos Remote Management
- CIU - Quick Guide
- Grundfos iSOLUTIONS MONITOR - Quick Guide



CIM modules instructions

- CIM 100/110 LON
- CIM 150 PROFIBUS DP
- CIM 200 Modbus RTU
- CIM 260 and CIM 280 cellular modules
- CIM 300 BACnet MS/TP
- CIM 500 Ethernet
- CIM 550 Ethernet Grundfos iSOLUTIONS Cloud
- CIM 040 TTL
- CIM 060
- GiM CIU

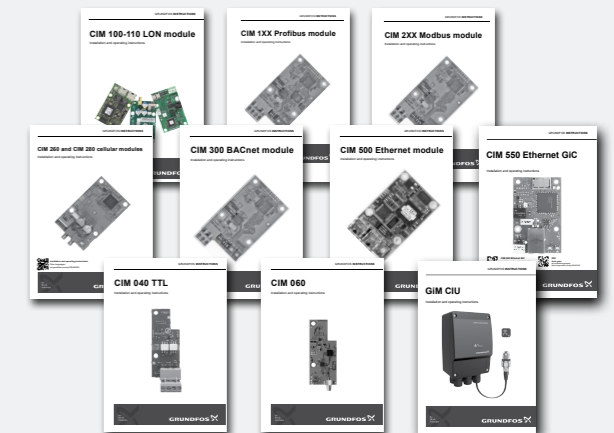

EICA Selection tool (Electrical Instrumentation, Control and Automation)

Grundfos has introduced for easy and simple selection of required fieldbus interfaces an online selection tool.

EICA tool contains:

- Selection of correct CIM interface
- Selection of documentation/manuals
- Selection of installation files
- PLC Programming examples for PROFIBUS/PROFINET

- PC Tool CIM/CIU
- Circuit diagrams

Select the relevant product (pump, controller) and the required BUS protocol type and the page will display all the information you need to efficiently handle your projects.

<https://www.grundfos-eica.com/>

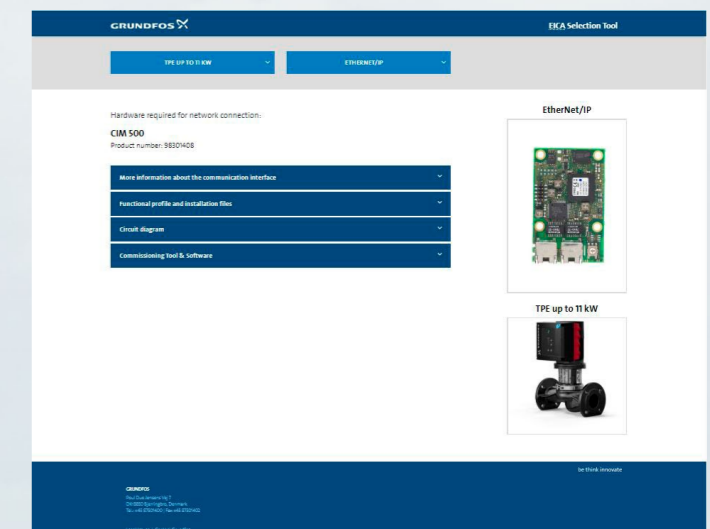
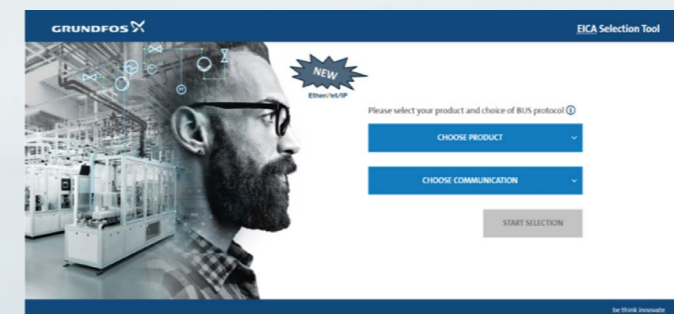

Advantages of Grundfos CIM/CIU communication interfaces

- Enables connection of any Grundfos pump or controller to a PLC, BMS/ SCADA system
- Pumps and controllers have better reliability with reduced downtime, due to monitoring and control functionality on a PLC, BMS/ SCADA system
- The operational cost of pumps can be lowered by reducing setpoints to match precise system needs via remote control
- Remote monitoring and control via PLC, BMS/ SCADA systems reduce manual settings, monitoring time and travel time to sites or installations
- Enable predictive maintenance and fast reaction time on process changes and exceptions
- Simple configuration of Fieldbus settings saves commissioning time
- Modular design – prepared for future needs
- Wide range 24-240 VAC/VDC power supply in CIU
- Easy to install, as Grundfos delivers the required support files and functional profile manuals

About Grundfos

Grundfos is one of the world's leading pump manufacturers and has been renowned for its innovative and reliable solutions since 1945. Today, we produce more than 16 million pump units every year for a wide range of application areas. Grundfos iSOLUTIONS brings a new era of intelligence to pump systems and water technology with solutions that look beyond individual components and optimise the entire system.

Learn more at www.grundfos.com